

| LIGHT             | MAKE # MODEL            | DC     | CIRC | APPLIANCE       | MAKE # MODEL           | DC     | CIRC |
|-------------------|-------------------------|--------|------|-----------------|------------------------|--------|------|
| A. LIVING ROOM    | THINLITE 716 (F15T8/CW) | 2.2 A  | #1   | 1. REFRIGERATOR | DOMETIC ROYAL RM3862   | 1.8 A  | #9   |
| B. KITCHEN GALLEY | THINLITE 112 (F8T5/CW)  | 1.4 A  | #2   | 2. FURNACE      | SUBURBAN SF-42         | 10.5 A | #7   |
| C. CEILING BATH + | THINLITE 712 (F8T5/CW)  | 1.4 A  | #2   | 3. WATER HEATER | SUBURBAN VDSI-6 6 GAL  | 1.0 A  | #6   |
| D. BED RM CEILING | THINLITE 712 (F8T5/CW)  | 1.4 A  | #3   | 4. WATER PUMP   | FLOJET 1104 QUAD DIAPH | 3.9 A  | #5   |
| E. WARDROBES      | PETERSEN V375S (1003)   | 0.94 A | #2,3 | 5. ATTIC (FAN)  | FANTASTIC 4000BT       | 2.5 A  | #4   |

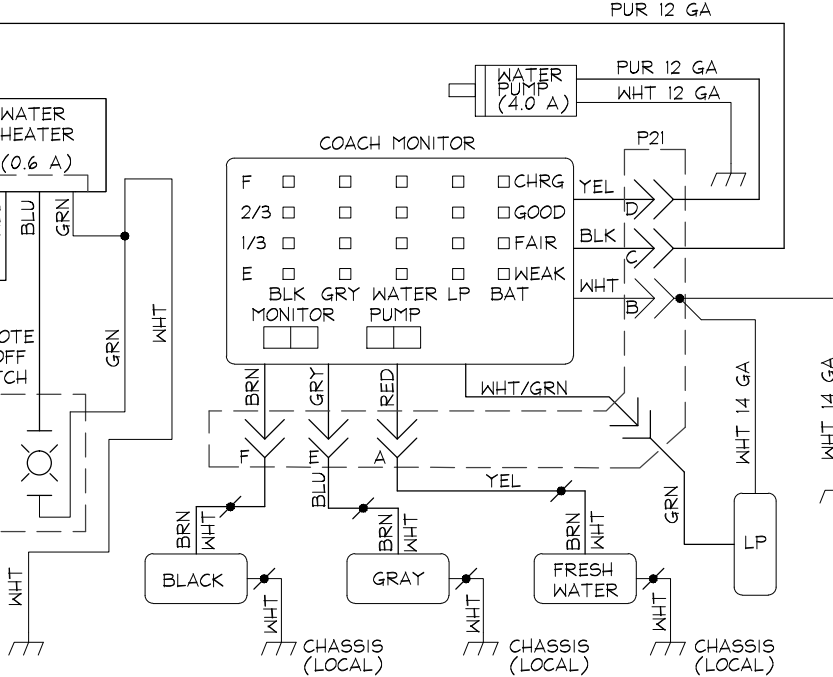
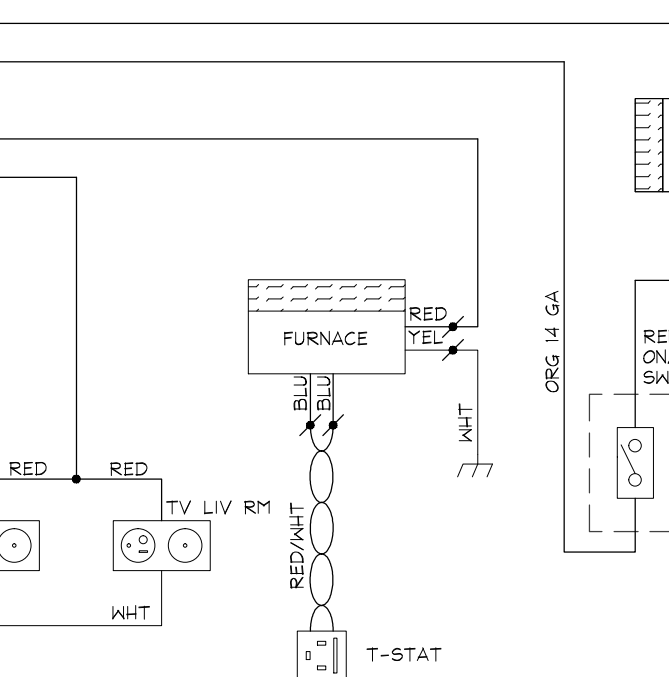
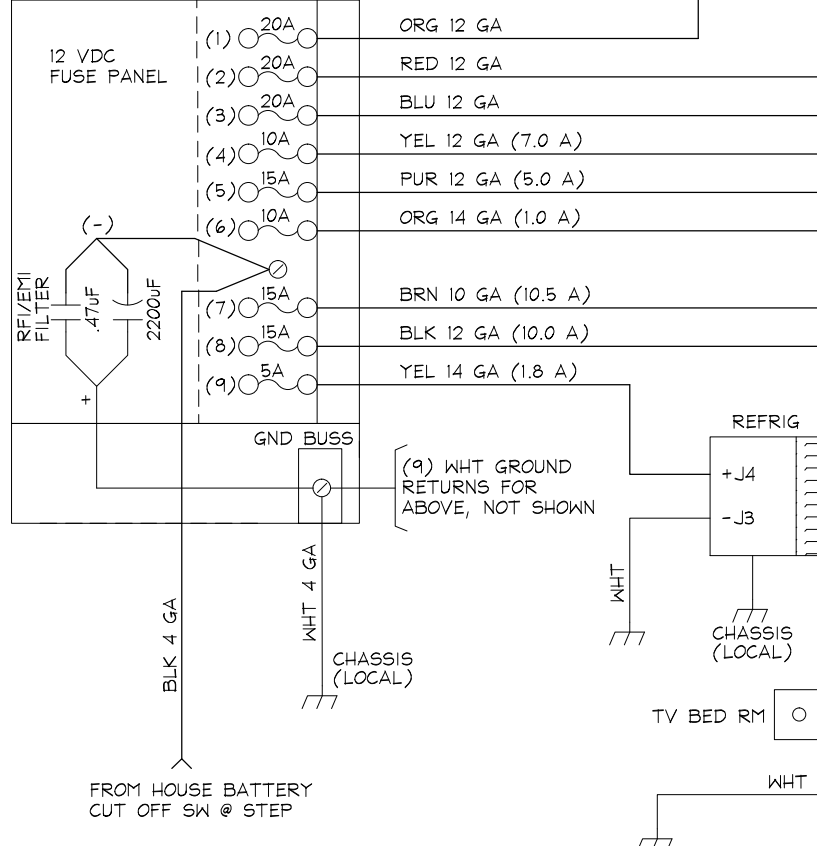
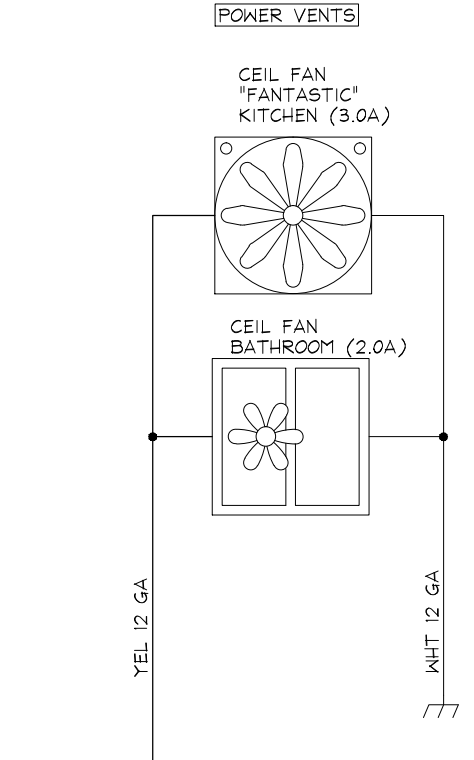
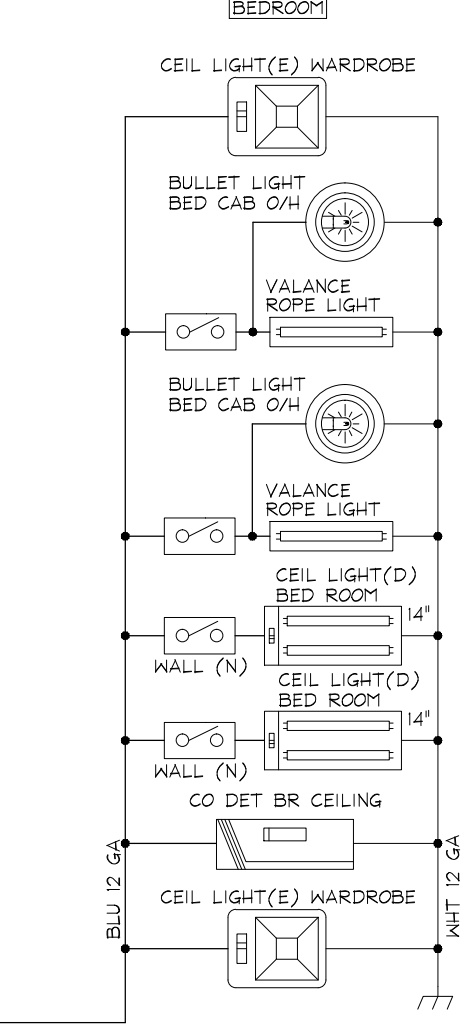
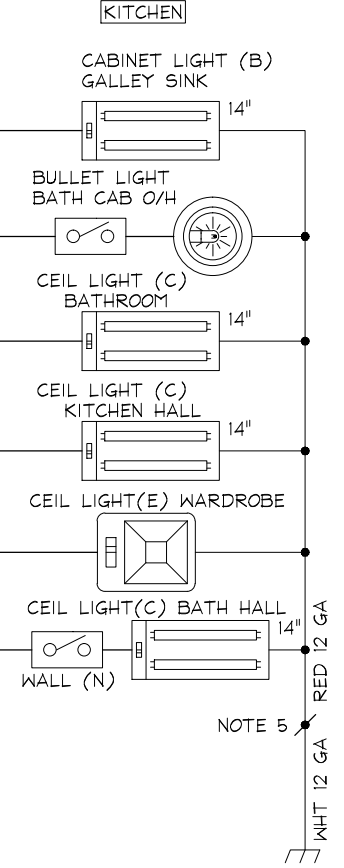
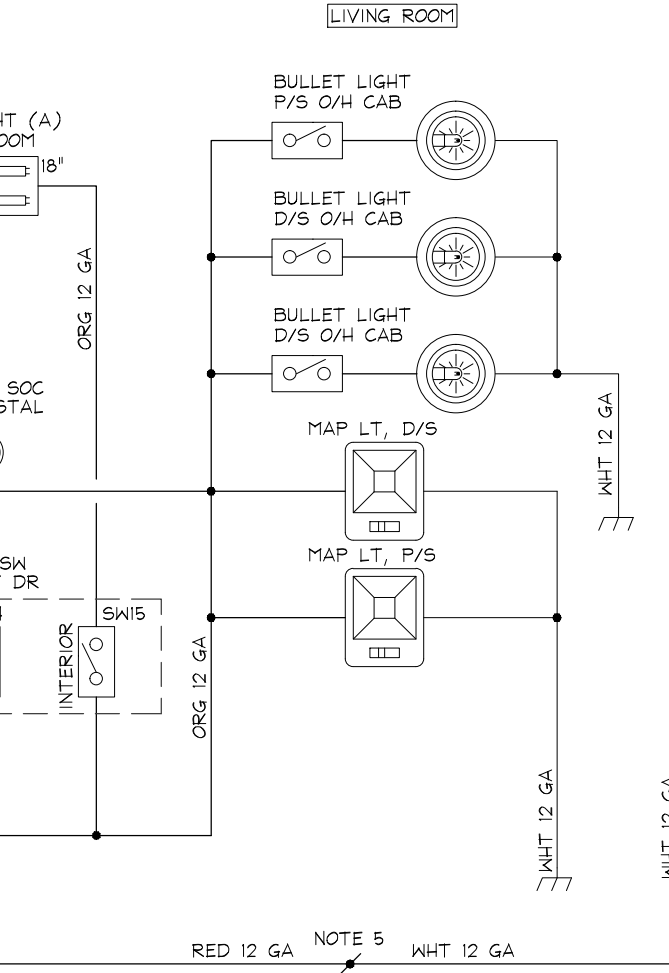
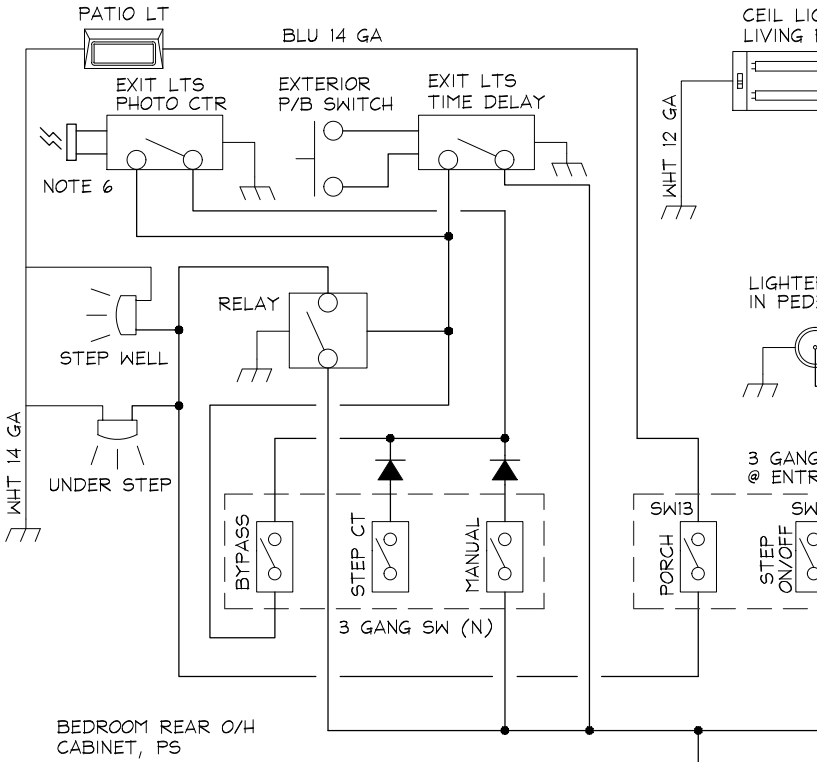

- NOTE:
- UNLESS NOTED,  $\text{---}$  ARE NOT LOCAL AND ARE RETURNED TO LOCAL FUSE PANEL.
  - UNLESS SHOWN, ON/OFF SWITCHES ARE PART OF THE DEVICE.
  - $\text{---}$  IS A WIRE NUT OR BUTT SPLICE.
  - WHT GROUND RETURNS ARE TO BE THE SAME SIZE AS THE SUPPLY WIRE.
  - RED (+) SUP CHANGES TO WHT BTW PNL & LTS. RED WAS POSSIBLY GROUND BY FASTENER DURING BUILD. AT LIGHTS, WHT=(+) & RED=(-). WIRES ARE TAGGED.
  - PHOTO CONTROL SENS MTD IN PATIO LIGHT.

|                                  |                                   |
|----------------------------------|-----------------------------------|
| 8/19/10                          | ADD EXIT LIGHTS TIME DELAY CIR    |
| 8/11/10                          | ADD EXIT LIGHTS PHOTO CONT + SW'S |
| SAFARI MOTOR COACHES, INC.       |                                   |
| BEDROOM BRKR/FUSE PANEL 12 VOLTS |                                   |
|                                  | 4/25/10                           |
| 1998 3044 SAHARA                 | 025E0305a                         |
| MOD FOR 1998                     | REDRAW: JIMX                      |